

VOL. 56 NO. 2 • FEBRUARY 2019

Mitchell EMC



The news
you need to
know in
5 minutes!

CAMILLA, GEORGIA
www.mitchellemc.com

Mitchell Electric Membership Corporation

82nd Annual Meeting

April 19, 2019

Mitchell EMC Auditorium • 475 Cairo Road, Camilla, GA 31730

Registration 12:30 - 2:00 p.m.

Information Booths 12:30 - 2:00 p.m.

Business Meeting 2:00 p.m.



**Entertainment
by
The Bowling Family
1:00 - 2:00 p.m.**

**FREE GIFTS to the
first 500 consumers
to register**



Mitchell EMC Scholarship Opportunities Available

Mitchell EMC is proud to offer two (2) scholarship opportunities for the youth of our area. We are currently accepting applications for the Walter Harrison Scholarship and our Operation Round Up Scholarships. Application forms and criteria can be found on our web site, www.mitchellemc.com.

Walter Harrison Scholarships:

• Mr. Walter Harrison was a pioneer in the electric industry in Georgia, and this scholarship is named in his honor and memory.



- It is a statewide \$1,000 scholarship.
- Scholarships are awarded based on academic achievement and financial need.
- Application deadline is **February 1, 2019**.

Operation Round Up Scholarships:

• Funds for these scholarships are provided by consumer participation in the Operation Round Up

program at Mitchell EMC.

• A maximum of fifteen (15) \$1,000 scholarships will be awarded to high school seniors and/or college/technical school students.

• Scholarships are awarded based on “All Around Student Performance” including academic performance, volunteerism, and participation in school, church and community activities. Financial need is also considered.

- Application deadline is **March 1, 2019**.



Please note that the scholarships have different deadlines and should be mailed to different addresses listed on the scholarship form. We encourage students to apply for both scholarships. Applications will be judged by an independent scholarship committee, and winners will be notified by May 1.

You're More Than a Customer

By Anne Prince

Author Anthony J. D'Angelo observed that, “Without a sense of caring, there can be no sense of community.”

To a large degree, this reflects Mitchell EMC's philosophy toward our consumer-members and the broader service territory that we serve. As a cooperative, we have a different “bottom line.” While our priority is always to provide reliable and safe energy, there is another equally important part of this equation. Your well-being and that of the larger community that we serve are of paramount concern.

To us, you are not just a customer; you are a member of our co-op and without you, we would not exist.

In 1937, Mitchell EMC was founded to fulfill a vital need in our community that would not have otherwise been met. Concerned local leaders came together to build this co-op and bring electricity where there was none.

At that time, members of the community understood we were different because they likely knew someone who helped to create Mitchell EMC. For most people, our founding and its circumstances have been long forgotten. Over time, folks in the community may have come to think of us as simply another energy provider. But we are not. We are a co-op that is constantly evolving to meet the needs of the communities we serve, and we are able to do this because of members like you.

Since our inception, we have sought feedback and engagement from you and that of the larger community to guide our long-term decisions. This is why we hold an annual meeting every year. We host events like

this to engage with you and obtain your feedback.

We strive to find new ways to help you use energy more efficiently. We're always looking to explore more options that will help you manage your energy use such as pre pay, TWACS reports, free home energy audits and rebates. In short, we are always seeking to keep pace with the changing energy environment, evolving technology and shifting consumer expectations.

Mitchell EMC members help guide important co-op decisions that improve and enrich the community. We value the perspective of our board members, who are members of the co-op and community – just like you.

As a local business, we have a stake in the community. That's why we support local charitable organizations such as the Alzheimer's Association, Boys and Girls Club, local Food Banks, Mitchell Baker Service Center and through our programs like Operation Roundup and Project Share. When you support these efforts, you are supporting the community and making it a better place for everyone.

While the times may have changed, our mission and outlook have not. We view our role as a catalyst for good. Working together, we can accomplish great things for our community now and in the future.

Anne Prince writes on consumer and cooperative affairs for the National Rural Electric Cooperative Association, the national trade association representing more than 900 local electric cooperatives. From growing suburbs to remote farming communities, electric co-ops serve as engines of economic development for 42 million Americans across 56 percent of the nation's landscape.

Types of Heat Pumps

There are three main types of heat pump systems. Use the information below to determine the system that's best suited for your climate and home.

Air-Source Heat Pumps

- Most commonly used heat pumps
- Moves heat rather than converting it from a fuel like combustion heating systems do
- Can reduce heating costs by about 50 percent when compared to baseboard heaters or electric furnaces
- Newer, more efficient systems now represent a legitimate space heating alternative in colder regions like the Northeast and Midwest.

Note: If temperatures in your area drop below 10 to 25 F, you will need an auxiliary heating system (depending on the size of the system).

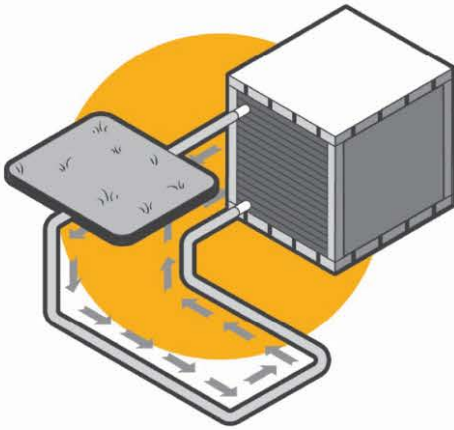
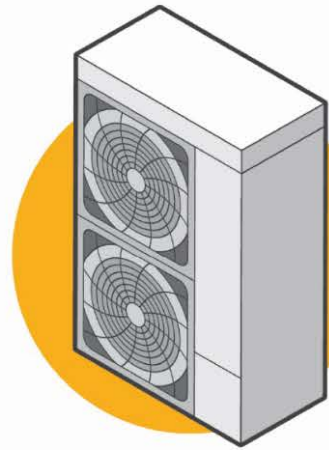

Geothermal Heat Pumps

- More expensive to install but provide more energy savings for heating and cooling
- Move heat through pipes buried underground
- When compared to a conventional heating system, can reduce energy use by 25 to 50 percent
- Effective in extreme climates
- Not ideal for smaller lots and certain soil conditions

Ductless Mini-Split Heat Pumps

- Easier to install, quiet, small in size
- Flexible for heating and cooling individual rooms and smaller spaces
- No energy loss through ductwork, which accounts for more than 30 percent of a home's energy use for space heating/cooling.
- Installation can be pricey, but federal incentives may be available

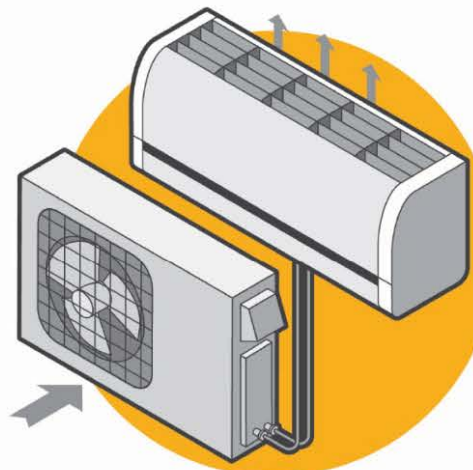

Heat pump systems should be installed by a licensed professional. Contact your local electric cooperative for more information about options and potential incentives.

Sources: Dept of Energy and Consumer Reports

Thank you for helping with Coat Cover-up Drive



Mitchell EMC would like to thank Westwood School's First Grade Class for helping us with the Coat Cover-up Drive. They donated many good used children's coats for needy kids in the area.

For over ten years, Mitchell EMC has collected winter coats, good used and new, for the needy at each of the district offices. The coat cover-up project is one that our employees and consumers enjoy doing every year. This year we collected over 200 coats that were donated to multiple area organizations in each of the district areas.

Energy Efficiency Tip of the Month

Laundry Tip: Dry towels and heavier cottons separately from lighter-weight clothing. You'll spend less time running the dryer for lighter-weight items, which saves energy.

Source: energy.gov



Note: If you move or no longer have electric service with Mitchell EMC, it is important that members keep their address current, so that future disbursements can be properly mailed. Capital credits are reserved for members even if they move out of the Mitchell EMC service area. Mitchell EMC will make a diligent effort to send a check by mail.

Statement of Equal Employment Opportunity

All applicants for employment shall be considered and hired on the basis of merit, without regard to race, color, religion, sex (including pregnancy), age, national origin, disability, genetic information, or past or present military status. The employment practices shall ensure equal treatment of all employees, without discrimination as to promotion, discharge, rates of pay, fringe benefits, job training, classification, referral, and other aspects of employment, on the basis of race, color, religion, sex (including pregnancy), national origin, disability, age, genetic information, or past or present military status. M/F/V/DV/D



WATT'S COOKING



Corn Casserole

Ingredients:

- 2 cans of creamed corn
- 3 eggs
- 2 tablespoons flour
- 1/2 stick melted butter

Combine all ingredients and pour them into a casserole dish. Cook on 350° for 25 minutes.

Thanks!

to

John Boyer,

Baker County, GA,
for sharing this recipe.

Share & Win!

Send us your favorite quick and easy dinner recipes. If your recipe is chosen for print, you can win a

\$25 credit

on your next Mitchell EMC bill.

Send recipes to

Heather Greene, P.O. Box 409, Camilla,
GA 31730 or email to
heather.greene@mitchellemc.com.